



7 Series

2- and 3-way 3-piece Bolted Ball Valves

Hoke 7 Series high performance, bi-directional ball valves exceed 50,000 cycles* with zero leakage**. The 7 Series includes an energized Teflon® stem seal and live loaded seats which require no adjustment over the life of the valve. 2-way valves can be configured for uni-directional flow by replacing standard seat rings with opposing curved disc spring seats. 7 series come standard in 316 stainless steel, and special alloys when requested. A variety of handles and remote actuation packages are available.



Technical Data

BODY MATERIAL	316 stainless steel
CYCLE LIFE	Exceeds 50,000
MAXIMUM OPERATING PRESSURE	2500 psig @70° F (172 bar @ 21° C)
OPERATING TEMPERATURE RANGE	-65° F to +500° F (-29° C to +232° C)
ORIFICE	0.19 to 0.81" (4.8 to 6mm)
Cv FACTORS	1.0 to 38

Features & Benefits

Energized Teflon® stem seal

- Exceeds 50,000 cycles, reducing costs of ownership*
- No packing adjustments required, providing operator peace of mind
- Low operating torque for ease of operation

Live-loaded seats

- Compensate for wear and temperature cycling with zero leakage, providing excellent durability and reliability.**
- Ensure leak-tight performance over entire pressure range simplifying ball valve specification and installation, saving time and expense.
- Optional vented ball equalizes pressure between ball orifice and center body cavity

Static -grounded stem

- Prevents static discharge for added safety
- Quarter turn handle provides a visual indication of on/off valve position, improving safety
- Stem flats provide visual indication of valve position, improving safety
- Bottom-loaded stem prevents stem blowout for added safety

- Optional trip-proof or latching / locking handle prevents accidental opening or closing of the valve for greater security and safety
- Fully encapsulated bolts are protected from the environment, extending valve life and reducing costs

Valves are designed, manufactured and tested in compliance with: ANSI/ASME B16.34 (valves: flanged, threaded, and welding end†), API 608 (metal ball valves: flanged, threaded and welding end), API 598 (valve inspection and test), and MSS SP-99 (instrument valves)

- Industry standards ensure reliability and integrity of components and systems

Top-mount actuators and brackets are designed and manufactured in compliance with ISO 5211 (industrial valve: part-turn actuator attachment)

- Allow HOKE 7 Series to easily interchange with a wide variety of pneumatic actuators
- Allow user to easily convert manual valve to pneumatic operation in the field
- Special High Tolerance NPT Thread

* For best results use a filter upstream of the valve. Dirty, erosive and corrosive fluids may affect the cycle life of the valve. Cycle life is based on working pressures less than 150 psig.

** Zero leakage per API 598.

† When B16.34 (option B) is selected, testing is conducted in accordance with these specifications.

HOKE Incorporated

405 Centura Court • PO Box 4866 (29305) • Spartanburg, SC 29303
Phone (864) 574-7966 Fax (864) 587-5608
www.hoke.com • sales@hoke.com

ball valves

Materials of Construction

Energized Teflon® Stem Seal Circular Elgiloy® spring contained within an inverted cup-shaped Teflon® packing ring applies constant dynamic radial force.

- *Low pressure operation:* Spring applies constant dynamic radial force from inside the Teflon® cup, effecting a constant dynamic seal against stem and body stuffing box.
- *High pressure operation:* Rising system pressure increases the force applied from inside the Teflon® cup, effecting a constant dynamic seal against stem and body stuffing box.
- *Thermal cycling and wear:* Spring applies constant dynamic radial force from inside the Teflon® cup, compensating for expansion and contraction of components due to thermal cycling and wear.

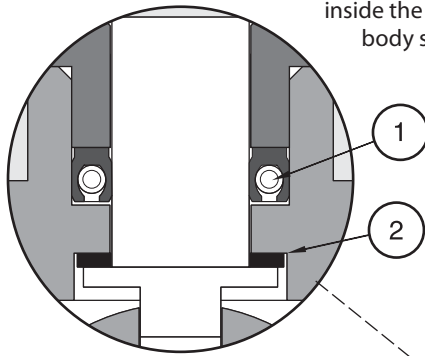

Energized Teflon Seal

Provides high cycle life, no packing adjustments required

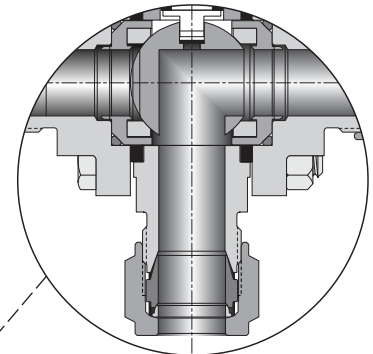

Third Port View
3-way Valve

Energized Seat Ring

(Upstream & Downstream)
Standard

Provides high cycle life, bi-directional flow & zero leakage

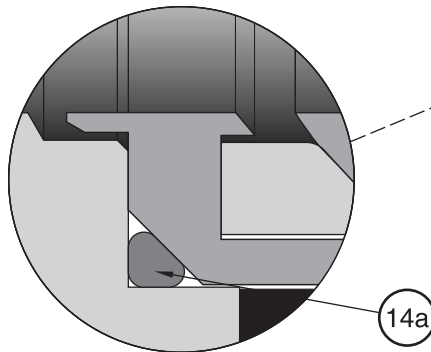

Energized Seat Rings Compressed O-rings apply constant dynamic force to the seat packing.

- *Low pressure operation:* Due to their resilient characteristics compressed O-rings apply constant dynamic force to the seats which make a leak tight seal against the ball.
- *High pressure operation:* Rising system pressure pushes the floating ball against the downstream seat enhancing the constant dynamic force generated by the O-rings which results in a leak-tight seal.
- *Thermal cycling and wear:* Due to their resilient characteristics compressed O-rings apply constant dynamic force to the seats, compensating for expansion and contraction of components due to thermal cycling and wear.
- *Bi-directional flow:* Energized seat rings utilizing compressed O-rings allow control of process fluid in both directions.

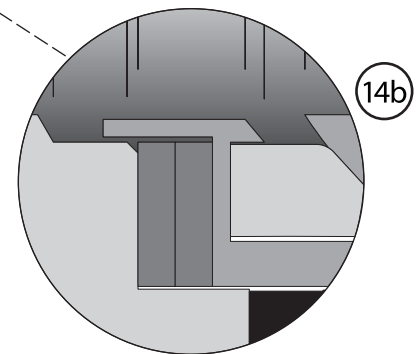
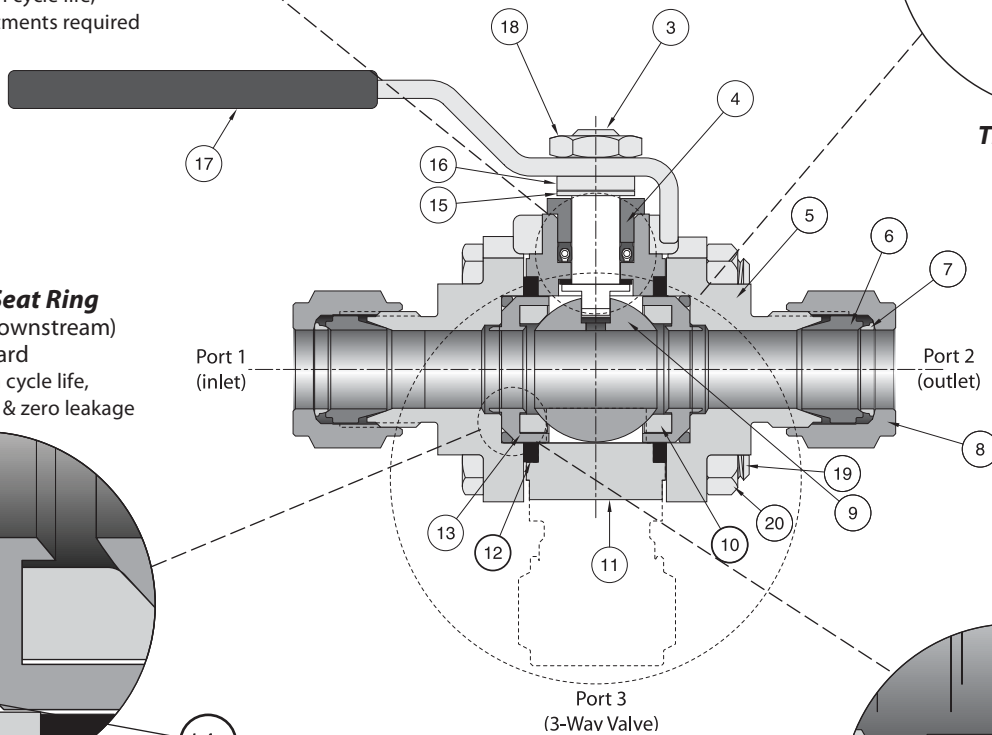

Optional Spring Loaded Seats Opposing curved disc spring seats (upstream only) in lieu of standard seat ring allow unidirectional flow.

- Available for 2-way valves only.
- Provide high cycle life and zero leakage.
- Located on upstream side only, no seat assembly is located on downstream side of ball for this option.

7 Series

Materials of Construction

316 Stainless Steel Valve with 'G' Seat and Seal Material – 15% Graphite filled Teflon® (standard)

	DESCRIPTION	COMPONENT MATERIAL	GRADE/ASTM SPECIFICATION
1	Energized Teflon® stem seal*	Graphite-filled Teflon®/Elgiloy®	—
2	Thrust washer*	PEEK™	—
3	Stem*	316 stainless steel	A479
4	Spacer	PEEK™	—
5	Adapter ends*	316 stainless steel	CF3M/A351
6	Ferrule, front*	316 stainless steel	A479
7	Ferrule, rear	316 stainless steel	A479
8	Gyrolok® nut	316 stainless steel	A479
9	Ball*	316 stainless steel	A479
10	Seat*	Graphite-filled Teflon®	—
11	Body*	316 stainless steel	CF3M/A351
12	Body seal*	PTFE	—
13	Seat retainer*	316 stainless steel	A479
14a	Energized seat ring (standard)*	FKM (Viton®)	MIL-R-83248
14b	Energized seat ring: curved disc springs (optional)*	316 stainless steel	—
15	Retaining ring	Stainless steel	PH15-7 MO
16	Handle spacer	316 stainless steel	A479
17	Handle	316 stainless steel	A240
18	Stem nut	316 stainless steel	ASTM A194 Grade 8
19	Body bolt	316 stainless steel	ASTM A193 B8
20	Body nut	316 stainless steel	ASTM A193 B8
	Handle stop roll pin (not shown, 7D Series only)	420 stainless steel	—
	Lubricant: Energized Teflon® stem seal	non silicone-based	Krytox® 104
	Lubricant: stem	non silicone-based	Krytox® 104
	Lubricant: seat	non silicone-based	Krytox® 206

* Wetted component

Technical Data (Standard)

SEAT	15% Graphite-filled Teflon®
BODY SEAL	PTFE
ENERGIZED STEM SEAL	Graphite-filled Teflon® / Elgiloy®
THRUST WASHER	PEEK™
MAXIMUM OPERATING PRESSURE*	2500 psig @ 70° F (172 bar @ 21° C)
TEMPERATURE RANGE (LIMITED BY SEAT RING MATERIAL)	FKM (Viton®): -20° F to +450° F (-29° C to +232° C) Curved Disc Springs: -65° F to +500° F (-54° C to +260° C)

* 3-way valves are limited to 1500 psig (103 bar)

Pressure vs. Temperature Curves

'G' Seat and Seal Material – 15% Graphite filled Teflon® (Standard)

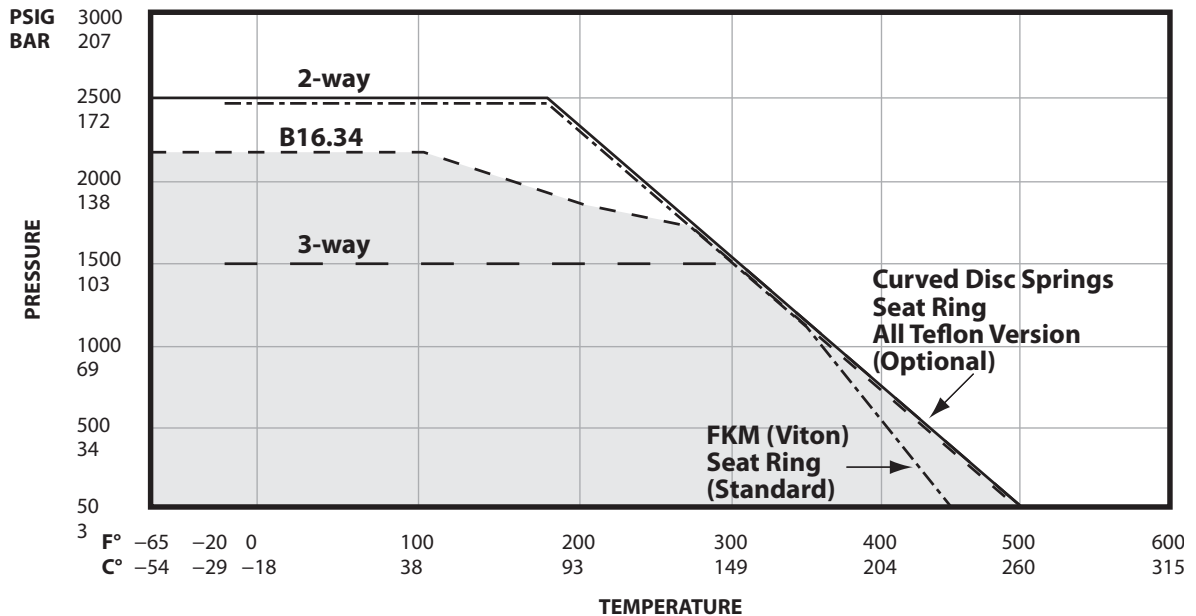

Pressure vs. Temperature Curves

These optional seat and seal materials are available through the 'Build to Order' matrix on pages 26 and 27.

'T' Seat and Seal Material –PTFE (Optional)

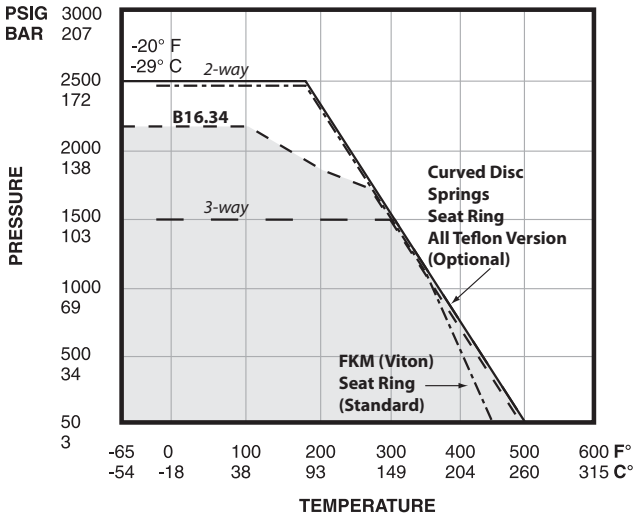

SEAT	PTFE
BODY SEAL	PTFE
ENERGIZED STEM SEAL	Graphite-filled Teflon® / Elgiloy®
THRUST WASHER	PEEK™
MAXIMUM OPERATING PRESSURE*	2500 psig @ 70° F (172 bar @ 21° C)
TEMPERATURE RANGE (LIMITED BY SEAT RING MATERIAL)	FKM (Viton®): -20° F to +450° F (-29° C to +232° C) Curved Disc Springs: -65° F to +500° F (-54° C to +260° C)

* 3-way valves limited to 1500 psig (103 bar).

'P' Seat and Seal Material –PEEK™ (Optional)

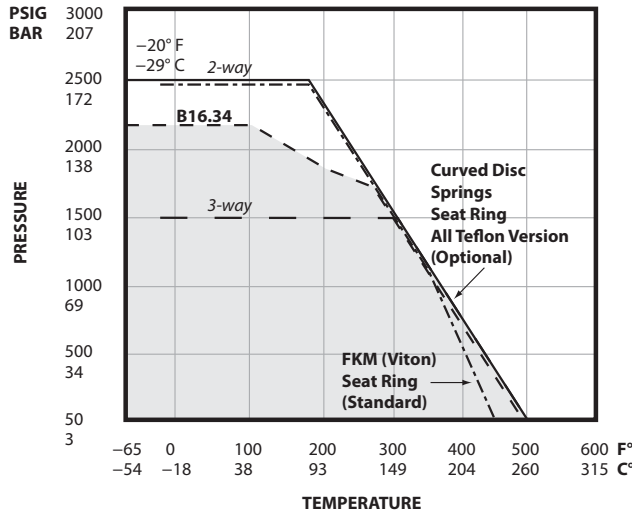

SEAT	PEEK™
BODY SEAL	PTFE
ENERGIZED STEM SEAL	Graphite-filled Teflon® / Elgiloy®
THRUST WASHER	PEEK™
MAXIMUM OPERATING PRESSURE*	2500 psig @ 70° F (172 bar @ 21° C)
TEMPERATURE RANGE (LIMITED BY SEAT RING MATERIAL)	FKM (Viton®): -20° F to +450° F (-29° C to +232° C) Curved Disc Springs: -65° F to +500° F (-54° C to +260° C)

* 3-way valves limited to 1500 psig (103 bar).

'U' Seat and Seal Material –UHMWPE (Optional)

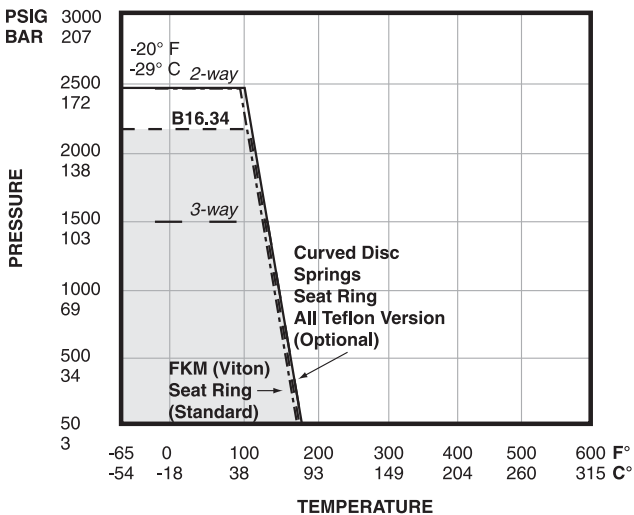

SEAT	UHMWPE
BODY SEAL	PTFE
ENERGIZED STEM SEAL	Graphite-filled Teflon® / Elgiloy®
THRUST WASHER	PEEK™
MAXIMUM OPERATING PRESSURE*	2500 psig @ 70° F (172 bar @ 21° C)
TEMPERATURE RANGE (LIMITED BY SEAT RING MATERIAL)	FKM (Viton®): -20° F to +180° F (-29° C to +82° C) Curved Disc Springs: -65° F to +180° F (-54° C to +82° C)

* 3-way valves limited to 1500 psig (103 bar).

7 Series

Pressure vs. Temperature Curves

These optional seat and seal materials are available through the 'Build to Order' matrix on pages 26 and 27.

'V' Seat and Seal Material –Virgin TFE (Optional)

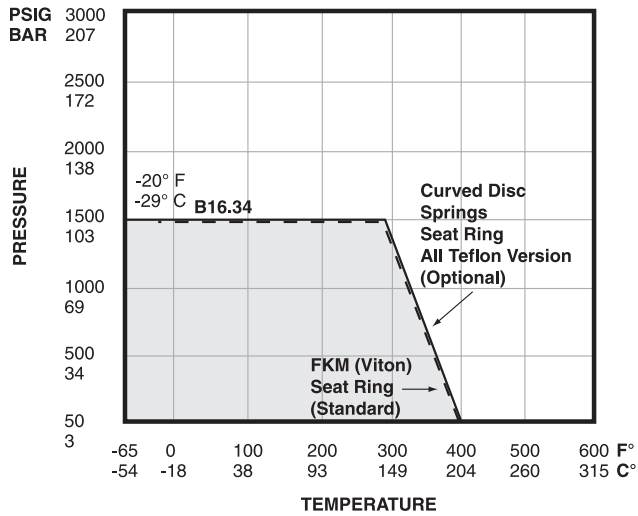

SEAT	TFE (virgin)
BODY SEAL	PTFE
ENERGIZED STEM SEAL	Graphite-filled Teflon® / Elgiloy®
THRUST WASHER	PEEK™
MAXIMUM OPERATING PRESSURE*	1500 psig @ 70° F (103 bar @ 21° C)
TEMPERATURE RANGE (LIMITED BY SEAT RING MATERIAL)	FKM (Viton®): -20° F to +400° F (-29° C to +204° C) Curved Disc Springs: -65° F to +400° F (-54° C to +204° C)

* 3-way valves limited to 1500 psig (103 bar).

'O' Seat and Seal Material –PTFE/FKM O-ring (Optional)

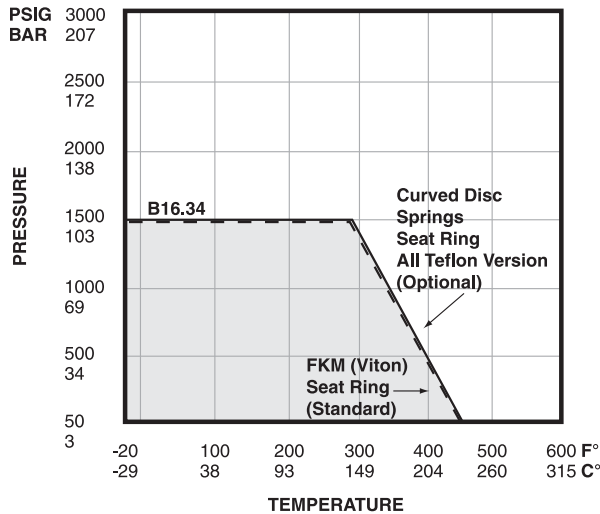

SEAT	PTFE
BODY SEAL	FKM (Viton®) o-ring
ENERGIZED STEM SEAL	Graphite-filled Teflon® / Elgiloy®
THRUST WASHER	PEEK™
MAXIMUM OPERATING PRESSURE*	1500 psig @ 70° F (103 bar @ 21° C)
TEMPERATURE RANGE (LIMITED BY SEAT RING MATERIAL)	FKM (Viton®): -20° F to +450° F (-29° C to +232° C) Curved Disc Springs: -20° F to +450° F (-29° C to +232° C)

* 3-way valves limited to 1500 psig (103 bar).

'R' Seat and Seal Material –PTFE/Reinforced PTFE (Optional)

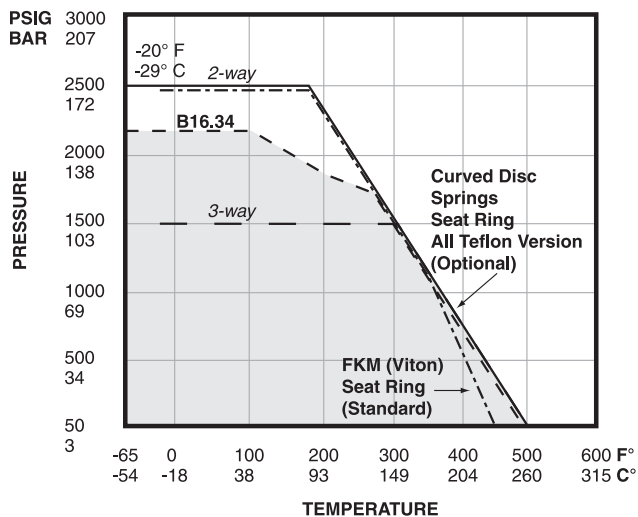

SEAT	PTFE
BODY SEAL	PTFE
ENERGIZED STEM SEAL	Graphite-filled Teflon® / Elgiloy®
THRUST WASHER	Reinforced PTFE
MAXIMUM OPERATING PRESSURE*	2500 psig @ 70° F (172 bar @ 21° C)
TEMPERATURE RANGE (LIMITED BY SEAT RING MATERIAL)	FKM (Viton®): -20° F to +450° F (-29° C to +232° C) Curved Disc Springs: -65° F to +500° F (-54° C to +260° C)

* 3-way valves limited to 1500 psig (103 bar).

7 Series

Dimensions: 7D Series (Cv Range = 1.0 to 3.8)

	2-WAY	3-WAY
ORIFICE SIZE	0.09" - 0.28" (2.3mm - 7.1mm)	0.09" - 0.20" (2.3mm - 5.1mm)
Cv RANGE	1.0 - 3.8	1.0 - 1.7

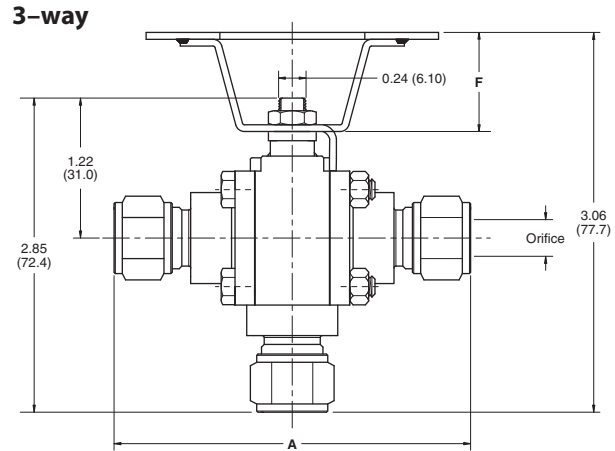
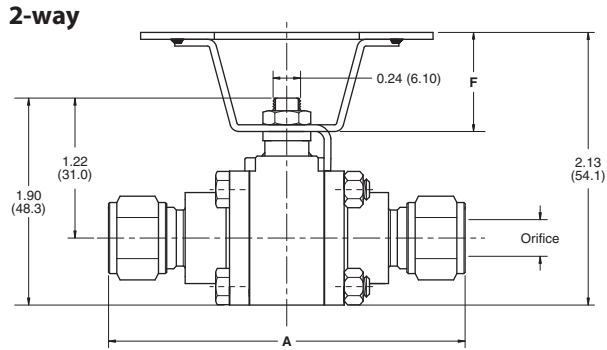
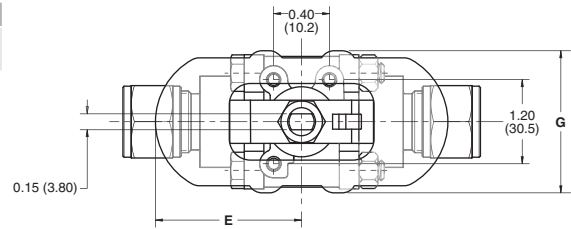

7D Series (Cv Range 1.0 to 3.8)

END CONNECTIONS	2-WAY			3-WAY			A
	BALL ORIFICE	ORIFICE*	Cv	BALL ORIFICE	ORIFICE*	Cv	
1/8" Gyrolok®	0.28"	0.09"	1.0	0.20"	0.09"	1.0	inch 3.38 mm 85.9
1/4" Gyrolok®	0.28"	0.19"	1.8	0.20"	0.19"	1.7	inch 3.38 mm 85.9
3/8" Gyrolok®	0.28"	0.28"	3.8	0.20"	0.20"	1.7	inch 3.38 mm 85.9
6mm Gyrolok®	0.28"	0.16"	1.3	0.20"	0.16"	1.7	inch 3.35 mm 85.1
8mm Gyrolok®	0.28"	0.23"	2.6	0.20"	0.20"	1.7	inch 3.35 mm 85.1
10mm Gyrolok®	0.28"	0.28"	3.8	0.20"	0.20"	1.7	inch 3.43 mm 87.1
1/4" female NPT	0.28"	0.28"	3.8	0.20"	0.20"	1.7	inch 2.29 mm 58.2
1/4" male NPT	0.28"	0.28"	3.8	0.20"	0.20"	1.7	inch 3.55 mm 90.2
1/4" Vaculok™	0.28"	0.28"	3.8	0.20"	0.20"	1.7	inch 3.59 mm 91.2
1/4" tube socket weld	0.28"	0.26"	3.4	0.20"	0.20"	1.7	inch 2.30 mm 58.4
3/8" tube socket weld	0.28"	0.28"	3.8	0.20"	0.20"	1.7	inch 2.50 mm 63.5
6mm tube socket weld	0.28"	0.25"	3.1	0.20"	0.20"	1.7	inch 2.50 mm 63.5
8mm tube socket weld	0.28"	0.28"	3.8	0.20"	0.20"	1.7	inch 2.50 mm 63.5
10mm tube socket weld	0.28"	0.28"	3.8	0.20"	0.20"	1.7	inch 2.50 mm 63.5
1/4" pipe butt weld sch 40	0.28"	0.28"	3.8	0.20"	0.20"	1.7	inch 1.97 mm 50.0
3/8" pipe butt weld sch 40	0.28"	0.28"	3.8	0.20"	0.20"	1.7	inch 1.97 mm 50.0
1/4" pipe socket weld sch 80	0.28"	0.28"	3.8	0.20"	0.20"	1.7	inch 2.35 mm 59.7
1/4" pipe butt weld sch 80	0.28"	0.28"	3.8	0.20"	0.20"	1.7	inch 1.97 mm 50.0
3/8" pipe butt weld sch 80	0.28"	0.28"	3.8	0.20"	0.20"	1.7	inch 1.97 mm 50.0

Handles

Oval handle

E 1.44" (36.6mm)

F 0.57" (14.5mm)

G 1.50" (38.1mm)

Lever handle

E 2.25" (57.2mm)

F 0.42" (10.8mm)

G 0.38" (9.65mm)

Consult factory for additional end connection sizes.

* Orifice diameter and flow rate listed for the total valve. The most restrictive orifice may be either the ball or the end connection orifice. Dimensions for reference only, subject to change.

7 Series

Dimensions: 7E Series (Cv Range = 4.0 to 12.5)

	2-WAY	3-WAY
ORIFICE SIZE	0.30" - 0.50" (7.6mm - 12.7mm)	0.30" - 0.42" (7.6mm - 10.7mm)
Cv RANGE	4.5 - 12.5	4.0

2-way

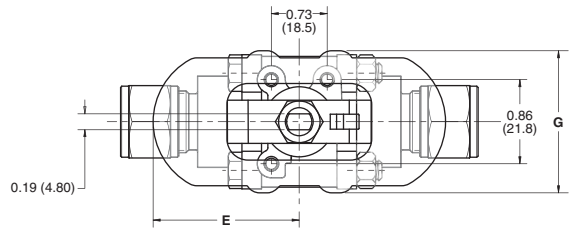
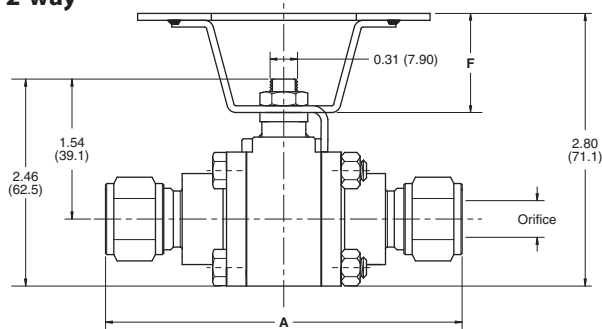

3-way

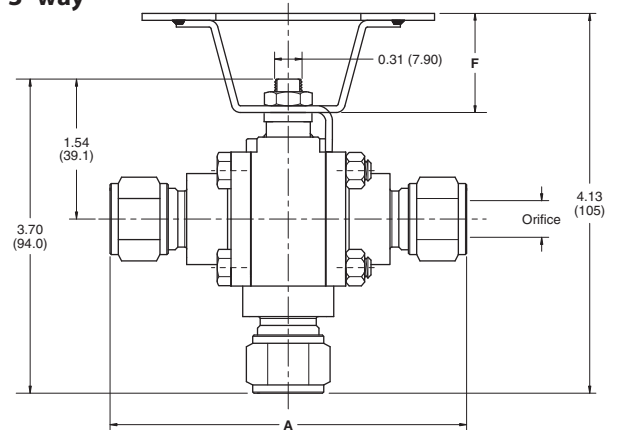

7E Series (Cv Range = 4.0 to 12.5)

END CONNECTIONS	2-WAY			3-WAY			A
	BALL ORIFICE	ORIFICE*	Cv	BALL ORIFICE	ORIFICE*	Cv	
3/8" Gyrolok®	0.50"	0.30"	4.5	0.42"	0.30"	4.0	inch 3.31 mm 84.1
1/2" Gyrolok®	0.50"	0.42"	7.5	0.42"	0.42"	4.0	inch 3.80 mm 96.5
3/4" Gyrolok®	0.50"	0.50"	12.5	0.42"	0.42"	4.0	inch 3.80 mm 96.5
12mm Gyrolok®	0.50"	0.39"	7.0	0.42"	0.39"	4.0	inch 3.80 mm 96.5
18mm Gyrolok®	0.50"	0.50"	12.5	0.42"	0.42"	4.0	inch 3.80 mm 96.5
3/8" female NPT	0.50"	0.50"	12.5	0.42"	0.42"	4.0	inch 3.25 mm 82.5
1/2" female NPT	0.50"	0.50"	12.5	0.42"	0.42"	4.0	inch 3.25 mm 82.5
1/2" Vaculok™	0.50"	0.50"	12.5	0.42"	0.42"	4.0	inch 3.27 mm 83.1
3/8" tube socket weld	0.50"	0.30"	4.5	0.42"	0.30"	4.0	inch 2.36 mm 59.9
1/2" tube socket weld	0.50"	0.42"	7.5	0.42"	0.42"	4.0	inch 2.36 mm 59.9
3/4" tube socket weld	0.50"	0.50"	12.5	0.42"	0.42"	4.0	inch 2.36 mm 59.9
12mm tube socket weld	0.50"	0.42"	7.5	0.42"	0.42"	4.0	inch 2.36 mm 59.9
18mm tube socket weld	0.50"	0.50"	12.5	0.42"	0.42"	4.0	inch 2.36 mm 59.9
3/8" pipe socket weld	0.50"	0.50"	12.5	0.42"	0.42"	4.0	inch 2.36 mm 59.9
1/2" pipe socket weld	0.50"	0.50"	12.5	0.42"	0.42"	4.0	inch 2.36 mm 59.9
3/8" pipe butt weld sch 40	0.50"	0.42"	7.5	0.42"	0.42"	4.0	inch 2.10 mm 53.3
1/2" pipe butt weld sch 40	0.50"	0.50"	12.5	0.42"	0.42"	4.0	inch 2.10 mm 53.3
3/8" pipe butt weld sch 80	0.50"	0.42"	7.5	0.42"	0.42"	4.0	inch 2.10 mm 53.3
1/2" pipe butt weld sch 80	0.50"	0.50"	12.5	0.42"	0.42"	4.0	inch 2.10 mm 53.3

Handles

Oval handle
E 2.14" (54.4mm)
F 1.50" (38.1mm)
G 2.08" (52.8mm)

Lever handle
E 3.72" (94.5mm)
F 0.62" (15.7mm)
G 0.63" (15.9mm)

Consult factory for additional end connection sizes.

* Orifice diameter and flow rate listed for the total valve. The most restrictive orifice may be either the ball or the end connection orifice. Dimensions for reference only, subject to change.

7 Series

Dimensions: 7F Series (Cv Range = 7.5 to 38.0)

	2-WAY	3-WAY
ORIFICE SIZE	0.42" - 0.88" (10.7mm - 22.4mm)	0.42" - 0.63" (10.7mm - 16.0mm)
Cv RANGE	7.5 - 38.0	9.0

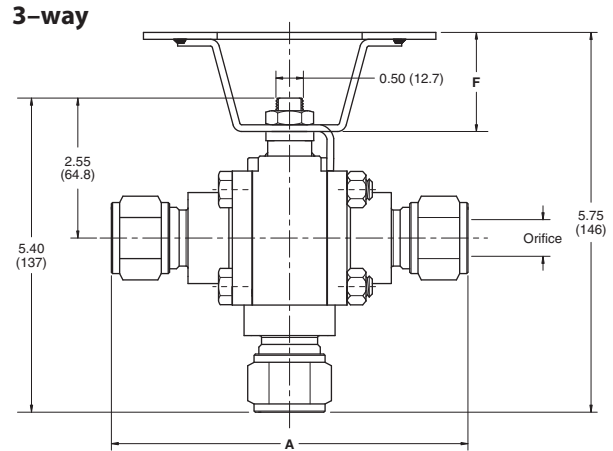
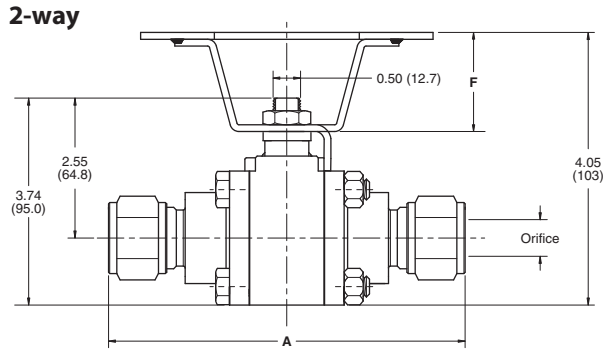
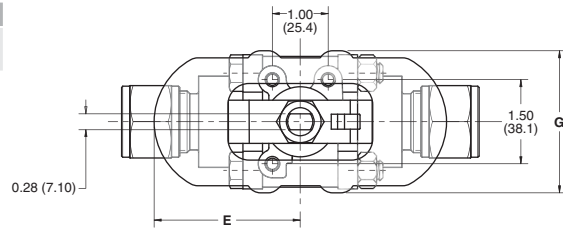

7F Series (Cv Range = 7.5 to 38.0)

END CONNECTIONS	2-WAY			3-WAY			A
	BALL ORIFICE	ORIFICE*	Cv	BALL ORIFICE	ORIFICE*	Cv	
1" Gyrolok®	0.88"	0.88"	38.0	0.63"	0.63"	9.0	inch 5.60 mm 142
25mm Gyrolok®	0.88"	0.88"	38.0	0.63"	0.63"	9.0	inch 3.69 mm 93.7
¾" female NPT sch 80	0.88"	0.88"	38.0	0.63"	0.63"	9.0	inch 3.69 mm 93.7
1" female NPT sch 80	0.88"	0.88"	38.0	0.63"	0.63"	9.0	inch 3.45 mm 87.6
1" tube socket weld	0.88"	0.88"	38.0	0.63"	0.63"	9.0	inch 3.45 mm 87.6
25mm tube socket weld	0.88"	0.88"	38.0	0.63"	0.63"	9.0	inch 3.45 mm 87.6
¾" pipe socket weld	0.88"	0.88"	38.0	0.63"	0.63"	9.0	inch 3.45 mm 87.6
1" pipe socket weld	0.88"	0.88"	38.0	0.63"	0.63"	9.0	inch 3.45 mm 87.6
¾" pipe butt weld sch 40	0.88"	0.75"	27.0	0.63"	0.63"	9.0	inch 3.45 mm 87.6
1" pipe butt weld sch 40	0.88"	0.88"	38.0	0.63"	0.63"	9.0	inch 3.45 mm 87.6
¾" pipe butt weld sch 80	0.88"	0.75"	27.0	0.63"	0.63"	9.0	inch 3.45 mm 87.6
1" pipe butt weld sch 80	0.88"	0.88"	38.0	0.63"	0.63"	9.0	inch 3.45 mm 87.6

Handles

Oval handle

- E** 2.61" (66.3mm)
- F** 1.75" (44.4mm)
- G** 2.54" (64.5mm)

Lever handle

- E** 5.44" (138mm)
- F** 0.80" (20.4mm)
- G** 0.75" (19.0mm)

Consult factory for additional end connection sizes.

* Orifice diameter and flow rate listed for the total valve. The most restrictive orifice may be either the ball or the end connection orifice. Dimensions for reference only, subject to change.

7 Series

Accessories: Handles

Lever Handle*



Handle Option "K"
316 Stainless Steel

* Standard handle for 7 Series

Oval Locking Handle

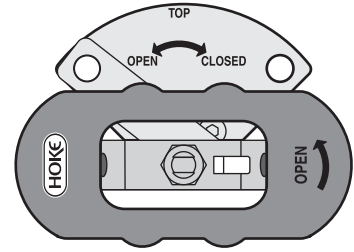

Handle Option "N"
316 Stainless Steel

Oval Locking/Latching Handle

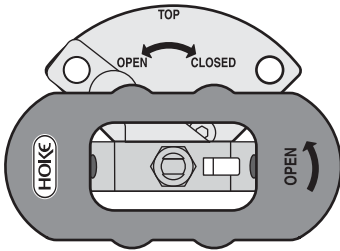

Handle Option "L"
316 Stainless Steel

Oval Handle

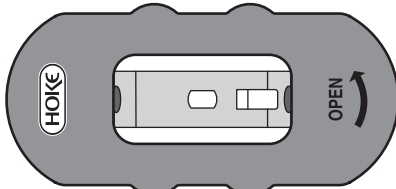

Handle Option "M" and "N"

M – Zinc-plated carbon steel
N – 316 stainless steel

Oval Extended Handle*

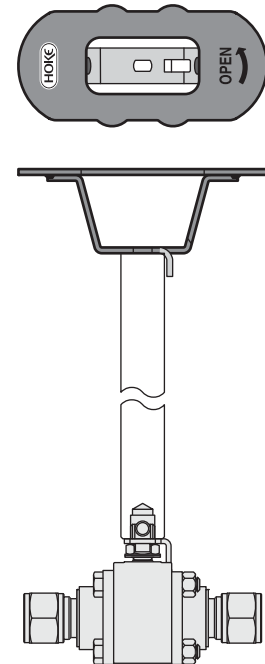

Handle Option "4"
316 Stainless Steel

Locking Lever Handle

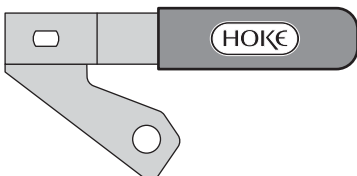

Handle Option "S"
316 Stainless Steel

7 Series

How to Order: Standard Valves

Use the following list to order standard valves that are readily available from your local HOKE distributor. If your application requires a customized valve, use the 'Build to Order' matrix on page 26 for 2-way valves or page 27 for 3-way valves.

All valves listed in this matrix are built with the following components as standard:

- 316 stainless steel body*
- 15% graphite-filled Teflon® seat*
- PTFE body seal*
- Graphite-filled Teflon®/316 stainless steel energized stem seal*
- PEEK™ thrust washer*
- 316 stainless steel body bolt
- 316 stainless steel ball*
- 316 stainless steel handle
- FKM (Viton®) seat rings*
- Standard cleaning

* Wetted components

2-way Valves

END CONNECTION (ALL PORTS)	END CONNECTION SIZE	ACTUATION METHOD	PART NUMBER
Gyrolok® <small>Metric Sizes 6mm, 8mm, 10mm, 12mm, 18mm, and 25mm are also available</small>	1/4"	Lever handle	7D2GG04G04YKS10V
	3/8"	Lever handle	7D2GG06G06YKS10V
	1/2"	Lever handle	7E2GG08G08YKS10V
	3/4"	Lever handle	7F2GG12G12YKS10V
	1"	Lever handle	7F2GG16G16YKS10V
	1/4"	Oval handle	7D2GG04G04YNS10V
	3/8"	Oval handle	7D2GG06G06YNS10V
	1/2"	Oval handle	7E2GG08G08YNS10V
	3/4"	Oval handle	7F2GG12G12YNS10V
	1"	Oval handle	7F2GG16G16YNS10V
	1/4"	Normally closed spring return pneumatic	7D2GG04G04Y6S10V
	3/8"	Normally closed spring return pneumatic	7D2GG06G06Y6S10V
	1/2"	Normally closed spring return pneumatic	7E2GG08G08Y6S10V
	3/4"	Normally closed spring return pneumatic	7F2GG12G12Y6S10V
	1"	Normally closed spring return pneumatic	7F2GG16G16Y6S10V
	Female NPT	1/4"	Lever handle
3/8"		Lever handle	7D2GF06F06YKS10V
1/2"		Lever handle	7E2GF08F08YKS10V
3/4"		Lever handle	7F2GF12F12YKS10V
1"		Lever handle	7F2GF16F16YKS10V
1/4"		Oval handle	7D2GF04F04YNS10V
3/8"		Oval handle	7D2GF06F06YNS10V
1/2"		Oval handle	7E2GF08F08YNS10V
3/4"		Oval handle	7F2GF12F12YNS10V
1"		Oval handle	7F2GF16F16YNS10V
1/4"		Normally closed spring return pneumatic	7D2GF04F04Y6S10V
3/8"		Normally closed spring return pneumatic	7D2GF06F06Y6S10V
1/2"		Normally closed spring return pneumatic	7E2GF08F08Y6S10V
3/4"		Normally closed spring return pneumatic	7F2GF12F12Y6S10V
1"		Normally closed spring return pneumatic	7F2GF16F16Y6S10V

3-way Valves

END CONNECTION (ALL PORTS)	END CONNECTION SIZE	ACTUATION METHOD	PART NUMBER
Gyrolok® <small>Metric Sizes 6mm, 8mm, 10mm, 12mm, 18mm, and 25mm are also available</small>	1/4"	Lever handle	7D3GG04G04G04YKS1V
	3/8"	Lever handle	7D3GG06G06G06YKS1V
	1/2"	Lever handle	7E3GG08G08G08YKS1V
	3/4"	Lever handle	7F3GG12G12G12YKS1V
	1"	Lever handle	7F3GG16G16G16YKS1V
	1/4"	Oval handle	7D3GG04G04G04YNS1V
	3/8"	Oval handle	7D3GG06G06G06YNS1V
	1/2"	Oval handle	7E3GG08G08G08YNS1V
	3/4"	Oval handle	7F3GG12G12G12YNS1V
	1"	Oval handle	7F2GG16G16G16YNS1V
	1/4"	Double acting pneumatic (switching)	7D3GG04G04G04Y5S1V
	3/8"	Double acting pneumatic (switching)	7D3GG06G06G06Y5S1V
	1/2"	Double acting pneumatic (switching)	7E3GG08G08G08Y5S1V
	3/4"	Double acting pneumatic (switching)	7F3GG12G12G12Y5S1V
	1"	Double acting pneumatic (switching)	7F3GG16G16G16Y5S1V

7 Series

How to Order: Build to Order for 2-way Valves

Use the matrix below to customize your 7 Series valve. Use the chart on page 25 to order standard, readily available 7 Series valves. **Standard items in bold.**

7E2 G G08 G08 Y K S 2 0 V

SERIES NUMBER

- 7D2** Cv Range 1.0 to 3.8
- 7E2** Cv Range 4.0 to 12.5
- 7F2** Cv Range 7.5 to 38.0
- (See pages 21-23)

SEAT & SEAL MATERIAL

- G** 15% Graphite filled Teflon®
 - T PTFE
 - P PEEK™
 - U UHMWPE
 - V Virgin TFE
 - O PTFE/FKM O-ring
 - R PTFE/Reinforced PTFE washer
- Consult factory if valve is actuated pneumatically*

Inlet PORT END

See 'Inlet / Outlet Ports' table below

Outlet PORT END

See 'Inlet / Outlet Ports' table below

WETTED METAL COMPONENTS

- Y** 316 stainless steel (standard)
- H Hastelloy® C-276
- M Monel® 400
- Consult factory for other materials

ACTUATION OPTIONS

Lever Handles (see page 24)

- K** 316 stainless steel (standard)
- S 316 stainless steel, locking

Ergonomic Oval Handles (see page 24)

- L 316 stainless steel, latching/locking
- M Zinc-plated carbon steel
- N 316 stainless steel
- 3 316 stainless steel, locking
- 4 316 stainless steel, extended (standard length = 4")**

Pneumatic Actuator†

- 5** Double acting (air to open/air to close)
- 6** Normally closed (spring returned)
- 7** Normally open (spring returned)

* Valves proof tested to 1.5x working pressure and tagged per B16.34.

** Consult factory for additional lengths.

† Refer to page 29 for specifications.

ANSI B16.34

Blank-Standard

- B** ANSI/ASME B16.34 Class 800*

SEAT RINGS

V FKM (Viton®) (standard)

- K** Kalrez® (-58° to +450° F / -50° to +232° C)
- E** EPDM (-65° to +250° F / -54° to +121° C)

Blank Seat rings are replaced with 2 opposing curved disc springs on upstream side. Valve becomes unidirectional when selecting this option. (Refer to drawing on bottom of page 17.)

Ball

0 Standard ball

- 1** Upstream vented ball, 316 stainless steel
- 2** Steam trap test valve

BODY BOLT, BODY NUT, AND STEM NUT

- 2** 316 stainless steel
- 3** 316 stainless steel -NACE compliant***

CLEANING OPTIONS

See page 27 for details

S Standard cleaning per HPS-1 and -2

A Industrial oxygen cleaning per HPS-18

B Chlorine service cleaning per HPS-172

*** Per NACE MR0175/ISO15156, the user must determine if this product is satisfactory for use in its intended environment.

Inlet / Outlet Ports

SERIES	SIZE	GYROLOK®	FEMALE NPT	TUBE SOCKET WELD	TUBE BUTT WELD	PIPE SOCKET WELD	SCH 80 PIPE BUTT WELD	SCH 40 PIPE BUTT WELD
7D2	1/8"	G02	—	—	—	—	—	—
	1/4"	G04	F04	T04	—	P04	B04	H04
	3/8"	G06	—	T06	—	—	B06	H06
	6mm	Z06	—	W06	—	—	—	—
	8mm	Z08	—	W08	—	—	—	—
	10mm	Z10	—	W10	—	—	—	—

Inlet / Outlet Ports

SERIES	SIZE	GYROLOK®	FEMALE NPT	TUBE SOCKET WELD	TUBE BUTT WELD	PIPE SOCKET WELD	SCH 80 PIPE BUTT WELD	SCH 40 PIPE BUTT WELD
7E2	1/4"	G04	F04	T04	S04	—	B04	—
	3/8"	G06	F06	T06	S06	P06	B06	H06
	1/2"	G08	F08	T08	S08	P08	B08	H08
	5/8"	G10	—	T10	—	—	—	—
	3/4"	G12	—	T12	S12	—	—	—
	1"	—	—	—	S16	—	—	—
	6mm	Z06	—	W06	—	—	—	—
	8mm	Z08	—	W08	—	—	—	—
	10mm	Z10	—	W10	—	—	—	—
	12mm	Z12	—	W12	—	—	—	—
7F2	14mm	Z14	—	W14	—	—	—	—
	15mm	Z15	—	W15	—	—	—	—
	16mm	Z16	—	W16	—	—	—	—
	18mm	Z18	—	W18	—	—	—	—
	3/4"	G12	F12	T12	—	P12	B12	H12
	3/8"	G14	—	—	—	—	—	—
	1"	G16	F16	T16	—	P16	B16	H16
	18mm	Z18	—	—	—	—	—	—
	20mm	Z20	—	—	—	—	—	—
	22mm	Z22	—	—	—	—	—	—
25mm	Z25	—	W25	—	—	—	—	

7 Series

How to Order: Build to Order for 3-way Valves

Use the matrix below to customize your 7 Series valve. Use the chart on page 25 to order standard, readily available 7 Series valves. **Standard items in bold.**

7E3 G G08 G08 G08 Y K S 2 V

SERIES NUMBER
7D3 Cv Range 1.0–3.8
7E3 Cv Range 4.0–12.5
7F3 Cv Range 7.5–38.0
 (See pages 20-22)

SEAT & SEAL MATERIAL
G 15% Graphite filled Teflon®
T PTFE
P PEEK™
U UHMWPE
V Virgin TFE
O PTFE/FKM O-ring
R PTFE/Reinforced PTFE washer
Consult factory if valve is actuated pneumatically

PORT 1 END
See 'Ports' table below

PORT 2 END
See 'Ports' table below

PORT 3 END
See 'Ports' table below

WETTED METAL COMPONENTS
Y 316 stainless steel (standard)
H Hastelloy® C-276
M Monel® 400
 Consult factory for other materials

ACTUATION OPTIONS
Lever Handles (see page 24)
K 316 stainless steel (standard)
S 316 stainless steel, locking

Ergonomic Oval Handles (see page 24)
3 316 stainless steel, locking
4 316 stainless steel, extended (standard length = 4")
L 316 stainless steel, latching/locking
M Zinc-plated carbon steel
N 316 stainless steel

Pneumatic Actuator†
5 Double acting (air to open/air to close, 180° rotation)
6 Spring return (180° rotation)

Cleaning Options
HPS-1 Cleaning procedure to remove oil and grease from metal valve parts with solvent vapor- and solvent ultrasonic vapor degreasers.
HPS-2 Cleaning procedure to remove dirt, oil, and grease from non-metallic parts with non-ionic detergent and water solution.
HPS-18 Cleaning procedure to remove oil, grease, and other contaminants from the valve and fitting components prior to assembly for industrial oxygen service.
HPS-172 Procedure to clean and package valve parts and assemblies for use with dry chlorine gas or liquid.

ANSI B16.34
Blank-Standard
B ANSI/ASME B16.34 Class 800*

SEAT RINGS
V FKM (Viton®) (standard)
K Kalrez® (-58° to +450° F / -50° to +232° C)
E EPDM (-65° to +250° F / -54° to +121° C)

BODY BOLT, BODY NUT, AND STEM NUT
2 316 stainless steel
3 316 stainless steel -NACE compliant**

CLEANING OPTIONS (see below)
S Standard cleaning per HPS-1 and -2
A Industrial oxygen cleaning per HPS-18
B Chlorine service cleaning per HPS-172

* Valves proof tested to 1.5x working pressure and tagged per B16.34.
 ** Per NACE MR0175/ISO15156, the user must determine if this product is satisfactory for use in its intended environment.
 † Refer to page 29 for specifications.

Port 1 / Port 2 / Port 3

SERIES	SIZE	GYROLOK®	FEMALE NPT	TUBE SOCKET WELD	TUBE BUTT WELD	PIPE SOCKET WELD	SCH 80 PIPE BUTT WELD	SCH 40 PIPE BUTT WELD
7D3	¼"	G02	—	—	—	—	—	—
	¼"	G04	F04	T04	—	P04	B04	H04
	⅜"	G06	—	T06	—	—	B06	H06
	6mm	Z06	—	W06	—	—	—	—
	8mm	Z08	—	W08	—	—	—	—
	10mm	Z10	—	W10	—	—	—	—
7E3	¼"	G04	F04	T04	S04	—	B04	—
	⅜"	G06	F06	T06	—	P06	B06	H06
	½"	G08	F08	T08	—	P08	B08	H08
	⅝"	G10	—	T10	—	—	—	—
	¾"	G12	—	T12	—	—	—	—
	1"	—	—	—	S16	—	—	—
	6mm	Z06	—	W06	—	—	—	—
	8mm	Z08	—	W08	—	—	—	—
	10mm	Z10	—	W10	—	—	—	—
	12mm	Z12	—	W12	—	—	—	—
7F3	14mm	Z14	—	W14	—	—	—	—
	15mm	Z15	—	W15	—	—	—	—
	16mm	Z16	—	W16	—	—	—	—
	18mm	Z18	—	W18	—	—	—	—
	¾"	G12	F12	T12	—	P12	B12	H12
	⅞"	G14	—	—	—	—	—	—
	1"	G16	F16	T16	—	P16	B16	H16
	18mm	Z18	—	—	—	—	—	—
	20mm	Z20	—	—	—	—	—	—
	22mm	Z22	—	—	—	—	—	—
25mm	Z25	—	W25	—	—	—	—	

7 Series – Accessories

NEMA 7 Position Monitor

Fully compatible with Hoke 07L Series pneumatic actuators, the NEMA 7 position monitor provides both electrical and visual verification of valve status. This device is especially useful in hard to reach areas including exhaust stacks, tanks, and areas where digital feedback is not readily available.

Features & Benefits

- Aluminum housing with powder-coated epoxy finish provides rugged protection for years of maintenance free service
- 90° Black/Yellow indicator provides clear position indication
- Separate 3/4" female threaded conduit openings for installation flexibility
- Setting system utilizes an internal leaf spring design that precisely positions and locks onto a splined shaft
- Cam system is easy to adjust, and includes a 303 stainless steel 1/4" NAMUR shaft
- Hermetically-sealed switches offer high level protection from moisture, shock, and corrosive environments for long life, accuracy and reliability



Technical Data

HOUSING	NEMA 7 Aluminum
BEARINGS	316 stainless steel
PROXIMITY SWITCHES	2 switches, 3-amps
VOLTAGE	120 Volts AC/DC
WATTAGE	100 Watts
OPERATING TEMPERATURE RANGE	-40° F to 257° F (-40° C to 125° C)
TERMINAL TYPE	8-pole fixed terminal strip
MOUNTING	80mm x 20mm NAMUR mounting

For field installation order number: ZASAC-21110

To order factory installation, add "/ZASAC-21110 to end of 7 Series part number

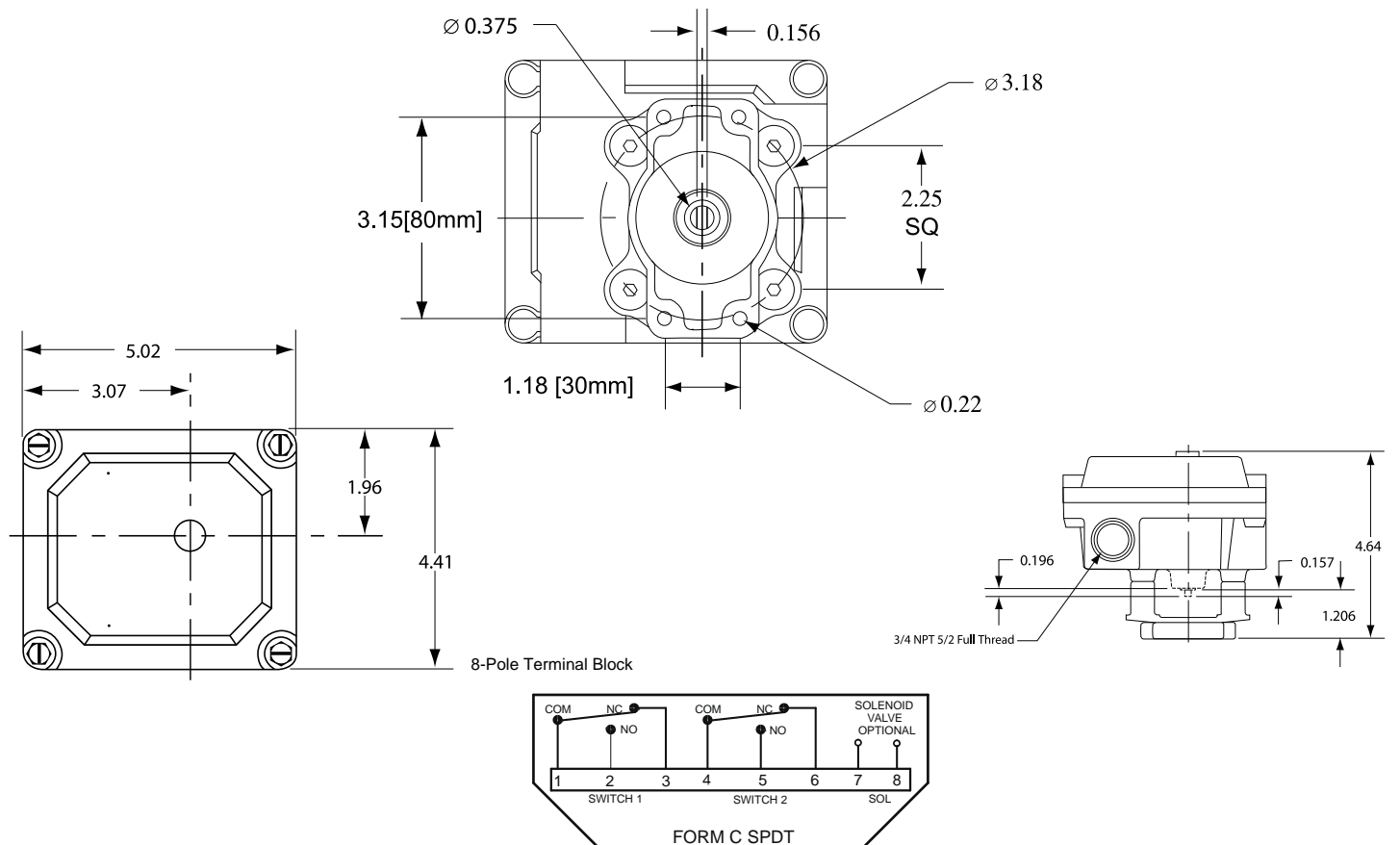

7 Series

Pneumatic Actuators

For remote actuation of 7 Series Ball Valves, order a pneumatic actuator and mounting kit for field assembly (see below) or use the "How to Order" guide on page 26 for factory assembly. Actuators for 7 Series are available in Double Acting (air to open and air to close) or Spring Return (normally open or normally closed) versions.

Features & Benefits

- Durable construction stands up to harsh environmental conditions, increasing durability and reliability.
- Compact size provides greater installation flexibility in tight spaces.
- Field assembled valve/actuator option provides simple conversion of manual valve to pneumatic operation. This increases flexibility and decreases installation costs.
- Top mounted actuator allows for conversion from manual valve to pneumatic operation without disrupting packing. Ensuring leak-tightness and improving reliability.
- Long cycle life results in reduced maintenance requirements and lower cost of ownership.

Limit switches, electro-pneumatic and electric actuators are available upon request. Please consult your local distributor.

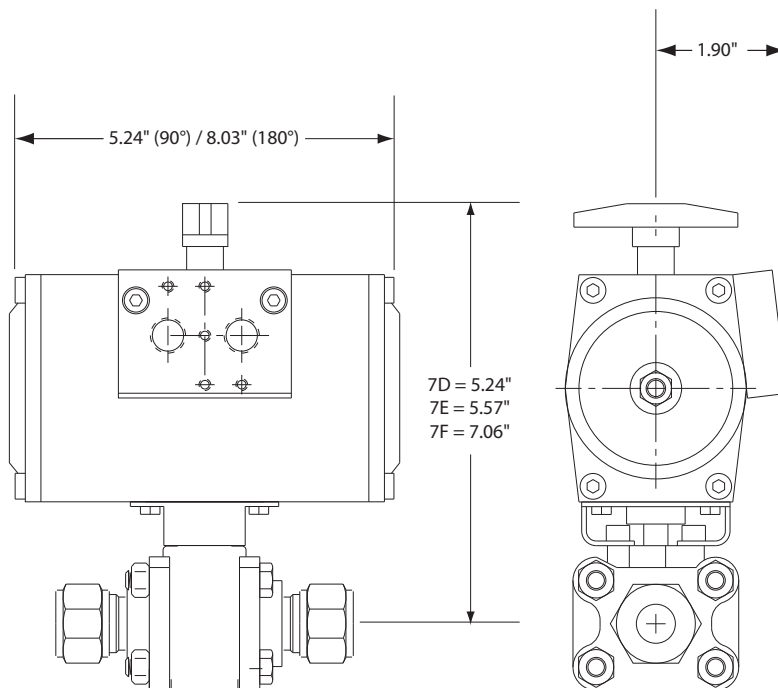

How to Order: Actuators and Mounting Kits

Actuator Pressure Requirements (Double Acting)

VALVE SERIES	DESCRIPTION	ACTUATOR PART NUMBER	MOUNTING KIT PART NUMBER	OPERATING TORQUE (IN LBS) FOR ACTUATOR INLET PRESSURE				
				40 PSIG	60 PSIG	80 PSIG	100 PSIG	120 PSIG
7D2	Double acting (90°)	07L90DA/ISO	7DM05K	151	227	302	378	453
7E2	Double acting (90°)	07L90DA/ISO	7EM05K					
7F2	Double acting (90°)	07L90DA/ISO	7FL07K					
7D3	Double acting (180°)	07L180DA/ISO	7DM05K					
7E3	Double acting (180°)	07L180DA/ISO	7EM05K					
7F3	Double acting (180°)	07L180DA/ISO	7FL07K					

Standard actuator operating temperature = -4° to $+194^{\circ}$ F (-20° C to $+90^{\circ}$ C); optional high temperature version to $+320^{\circ}$ F ($+160^{\circ}$ C).

Actuator Pressure Requirements (Spring Return)

VALVE SERIES	DESCRIPTION	ACTUATOR PART NUMBER	MOUNTING KIT PART NUMBER	OPERATING TORQUE (IN LBS) FOR ACTUATOR INLET PRESSURE										CLOSING FORCE (IN LBS)
				40 PSIG		60 PSIG		80 PSIG		100 PSIG		120 PSIG		
				START	END	START	END	START	END	START	END	START	END	
7D2	Spring Return	07L90SR2/ISO	7DM05K	69	93	144	168	218	242	293	317	367	391	38
7E2	Spring Return	07L90SR2/ISO	7EM05K											
7F2	Spring Return	07L90SR2/ISO	7FL07K											
7D3	Spring Return	07L180SR2/ISO	7DM05K											
7E3	Spring Return	07L180SR2/ISO	7EM05K											
7F3	Spring Return	07L180SR2/ISO	7FL07K											

Standard actuator operating temperature = -4° to $+194^{\circ}$ F (-20° C to $+90^{\circ}$ C); optional high temperature version to $+320^{\circ}$ F ($+160^{\circ}$ C).

7 Series

Valve Spare Parts

Kit contents: Seats, energized Teflon® stem seals, thrust washer, body seal, TFR-61 rebuild instructions. **Standard items in bold.**

R7 E G V

Valve Size

- D (Cv Range 1.0 to 3.8)**
- E (Cv Range 4.0 to 12.5)**
- F (Cv Range 7.5 to 38.0)**

Seat & Stem Seal Material

See 'Seat & Stem Seal Materials' table below

Energized Seat Ring Material

- V FKM (Viton®), standard**
- E** EPDM (–65° F to +250° F / –54° C to +121° C)
- K** Kalrez® (–58° F to +450° F / –50° C to +232° C)
- Blank** Seat rings are replaced with 2 opposing curved disc springs on upstream side. Valve becomes uni-directional when choosing this option. Not available on 3-way valves.

Seat & Stem Seal Materials

DESIGNATOR	SEAT	ENERGIZED STEM SEALS	BODY SEAL	THRUST WASHER
G (standard)	15% graphite-filled Teflon®	Graphite-filled Teflon®/Elgiloy®	PTFE	PTFE
O	PTFE	Graphite-filled Teflon®/Elgiloy®	FKM (Viton®) o-ring	PEEK™
P	PEEK™	Graphite-filled Teflon®/Elgiloy®	PTFE	PEEK™
R	PTFE	Graphite-filled Teflon®/Elgiloy®	PTFE	PTFE
T	PTFE	Graphite-filled Teflon®/Elgiloy®	PTFE	PEEK™
U	UHMWPE	Graphite-filled Teflon®/Elgiloy®	PTFE	PEEK™
V	TFE (Viton®)	Graphite-filled Teflon®/Elgiloy®	PTFE	PEEK™

For Your Safety

It is solely the responsibility of the system designer and user to select products suitable for their specific application requirements and to ensure proper installation, operation, and maintenance of these products. Material compatibility, product ratings and application details should be considered in the selection. Improper selection or use of products described herein can cause personal injury or property damage.

VCR® is a registered trademark of Cajon Co.

Dow Corning® is a registered trademark of Dow Corning Corporation

Nylatron® is a registered trademark of DSM Engineering Plastic Products

Teflon® is a registered trademark of the DuPont Company

Kalrez® and Viton® are registered trademarks of DuPont DOW Elastomers

Dyneon™ is a trademark of Dyneon

Elgiloy® is a registered trademark of Elgiloy Specialty Metals

Gyrolok®, Dyna-Pak®, Rotoball®, Flomite®, Selectomite®, and Multimite® are registered trademarks of HOKE, Inc.

Space Saver™, Ultramite™, and Vaculok™ are trademarks of HOKE, Inc.

Rulon® is a registered trademark of Saint-Gobain Corporation

Monel® and Inconel® are registered trademarks of Special Metals Corporation

Swagelok® is a registered trademark of Swagelok Company

Grafoil® is a registered trademark of GrafTech International, Inc.

PEEK™ is a trademark of Victrex PLC

www.dowcorning.com

www.dsm.com

www.dupont-dow.com

www.3m.com

www.elgiloy.com

www.hoke.com

www.hoke.com

www.saint-gobain.com

www.specialmetals.com

www.swagelok.com

www.graftech.com

www.victrex.com