

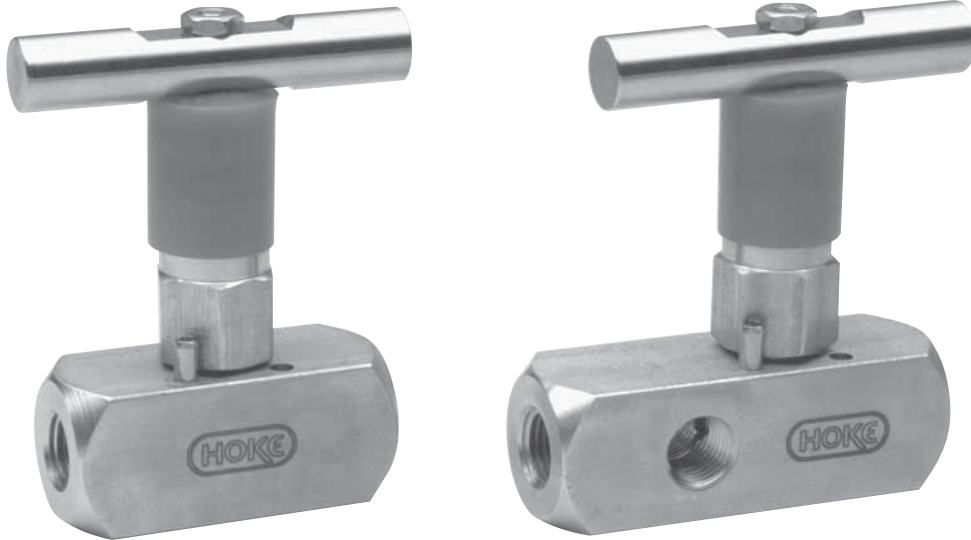

7400 Series

Rising Stem Plug Valve



Benefits

Safety

- Back seating is standard

Straight through flow

- In the full open position, the unobstructed, straight through flow path provides maximum flow and rodability

Regulating capability

- A tapered plug and conical seat provide flow regulation and reliable shutoff with very low seating torque, similar to that of a needle valve

Helps reduce fugitive emissions

- Dyna-Pak® packing provides a leak-tight seal with low operating torque in deep vacuum or high pressure applications

Extended valve life

- Soft Delrin® seat can absorb solid contaminants and still provide leak-tight shutoff. Delrin® maintains its toughness and remains springy under a wide range of temperature conditions, enduring high fatigue and resisting both creep and corrosion

Dependability

- All valves are tested for bubble-tight leakage at both seat and packing

Typical Applications

- Lines which contain small solid impurities
- Instrumentation lines which contain viscous fluids or slurries
- Systems which require routine cleaning
- Systems which require flow regulation and full flow capabilities

Technical Data

MAXIMUM OPERATING PRESSURE	6,000 psig @ 70° F (41.4 MPa @ 21° C)
OPERATING TEMPERATURE RANGE	-20° to 250° F (-29° C to 121° C)
ORIFICE SIZES	0.187 and 0.250
Cv FACTORS	0.83 and 1.20
END CONNECTIONS	¼ to ½ NPT

HOKE Incorporated
405 Centura Court • Spartanburg, SC 29303
Phone (864) 574-7966 Fax (864) 587-5608
www.hoke.com • sales@hoke.com

plug valves

7400 Series

Materials of Construction

Body	316 stainless steel
Bonnet	316 stainless steel
Stem	17-4PH stainless steel
Disc	17-7 stainless steel
Plug	316 stainless steel
Seat	Delrin®
Stem packing	TFE/316 stainless steel
Packing nut	XM-28 stainless steel
Lock nut	316 stainless steel
Handle	316 stainless steel
Dust cover	Polyethylene

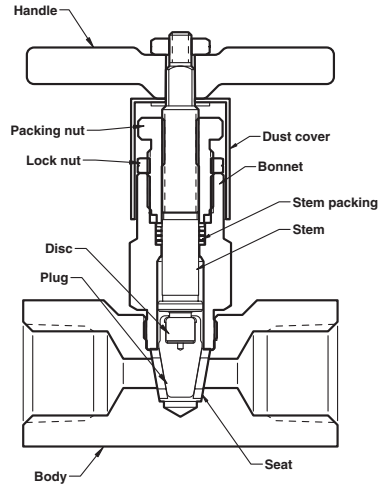

Flow Curve

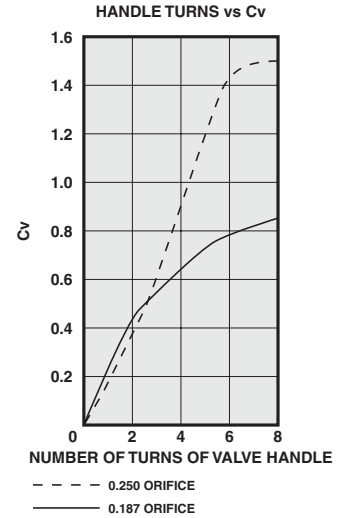

Valve Ordering Chart



7451F4Y

END CONNECTIONS		ORDER BY PART NUMBER			
INLET	OUTLET	STANDARD	GAUGE PORTING	ORIFICE	Cv
¼ female NPT	¼ female NPT	7451F4Y	7471F4Y	0.187	0.83
½ female NPT	½ female NPT	7461F8Y	—	0.250	1.20
½ male NPT	½ female NPT	7461L8Y	—	0.250	1.20

Other end configurations, including HOKE Gyrolok®, are available. Please contact your local HOKE distributor for details.

Dimensions Chart

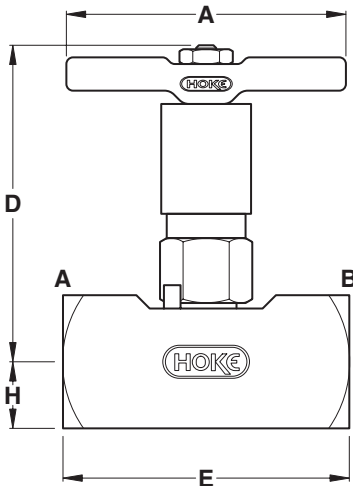

INLET A	OUTLET B		D	E	F	H
¼ female NPT	¼ female NPT	inch	3 ⁷ / ₃₂	2 ¹ / ₄	2 ⁵ / ₈	½
¼ female NPT	¼ female NPT	mm	82	57	67	13
¼ female NPT	¼ female NPT Gauge porting	inch	3 ⁷ / ₃₂	2 ⁷ / ₈	2 ⁵ / ₈	½
		mm	82	73	67	13
½ female NPT	½ female NPT	inch	3 ⁷ / ₃₂	2 ²¹ / ₃₂	2 ⁵ / ₈	½
		mm	82	68	67	13
½ male NPT	½ female NPT	inch	3 ⁷ / ₃₂	3 ¹ / ₂	2 ⁵ / ₈	½
		mm	82	89	67	13

For Your Safety

It is solely the responsibility of the system designer and user to select products suitable for their specific application requirements and to ensure proper installation, operation, and maintenance of these products. Material compatibility, product ratings and application details should be considered in the selection. Improper selection or use of products described herein can cause personal injury or property damage.