

## PR-11 Series

Ultra Sensitive Pressure Control Regulator



This precision pressure regulator has been designed to allow the user complete flexibility in application. The instrument design engineer can now choose the optimum operating parameters he needs for a particular flow system.

Flow and pressure regulation can now be easily and economically accomplished in laboratory and process chromatographs, air pollution analyzers and other general process and laboratory instruments. The low internal volume and no trapped areas mean efficient operation and cleanliness in instrumentation with high sensitivity detectors. The standard stainless diaphragm prevents permeability of undesired contaminants into the flow stream.

This regulator offers greater pressure and flow stability for critical applications such as chemiluminescent type analyzers and is considered the ultimate in maximum stability with ambient temperature change. The PR-11 Series has truly been designed by experienced instrumentation engineers for use in that industry.

### Features & Specifications

- Single stage precision regulation in a compact design package
- Bubble-tight shutoff
- Pressure gauge and relief valve ports optional
- Teflon® lined stainless steel or Viton® diaphragm standard
- Outlet pressure ranges 0–10, 0–25, 0–50, 0–100, 0–250 and 0–500 psig
- 40 micron inlet filter
- Suitable for gas or liquid service
- Panel mounting ½" diameter, standard
- ¼" FNPT connections
- Inlet pressures to 3600 psig
- Cv flow coefficient of 0.025, 0.06, and 0.20
- Materials in contact with operating media are aluminum, 300 series stainless steel, Viton®, Teflon® and Inconel

### Options

- ¼" FNPT connection
- Extra ports
- Pressure gauges
- Panel mount, (requires a 1⅜" mounting hole)

### GO Regulator

405 Centura Court • PO Box 4866 • Spartanburg, SC 29303  
Phone (864) 574-7966 Fax (864) 574-5608  
www.goreg.com • sales@goreg.com

pressure regulators

# PR-11 Series

## How to Order

### PR11 -

#### BODY MATERIAL

- 3 Aluminum

#### PORT CONFIGURATION

- A Standard

For more port configurations, see page 35

#### PROCESS PORT TYPES

(GAUGE PORT TYPES, IF SPECIFIED)

- 0 1/8" FNPT (1/8" FNPT gauge ports)  
1 1/4" FNPT (1/4" FNPT gauge ports)

#### SURFACE FINISH OF DIAPHRAGM CAVITY

- 1 < 25 Ra

#### SEAT MATERIAL

- A Tefzel®  
B CF Teflon®  
C Polyimide  
D Viton® (0.2 Cv only)  
H PCTFE (formerly Kel-F® 81)  
I High density Teflon®  
Q PEEK™

#### CAP ASSEMBLY

- 1 Standard, stainless steel  
2 Old style PR-10 topworks, aluminum  
4 1 3/8" panel mount, aluminum

#### DIAPHRAGM FACING/BACKING MATERIAL

- 1 Teflon®/stainless steel  
2 Teflon®/Viton®

#### DIAPHRAGM TYPE

- 1 Standard  
2 Standard, NiSpan range spring  
3 Self-relieving  
4 Self-relieving, NiSpan range spring

#### OUTLET RANGE

- C 0-10 psig  
D 0-25 psig  
E 0-50 psig  
G 0-100 psig  
I 0-250 psig

#### FLOW COEFFICIENT (Cv)

- 3 0.06  
5 0.2  
C 0.025

NOTE: The choices above represent an abbreviated list of the more commonly ordered options. For a complete listing of all available options, please see the Selection Wizard on the GO website at [www.goreg.com](http://www.goreg.com) or contact the factory.

## Maximum Temperature & Operating Inlet Pressures

SEAT MATERIAL	MAXIMUM TEMPERATURE	@	MAXIMUM OPERATING INLET PRESSURE
Viton®	225° F (107° C)	@	300 psig (2.07 MPa)
Tefzel®	150° F (66° C)	@	3600 psig (24.82 MPa)
High density Teflon®	150° F (66° C)	@	3600 psig (24.82 MPa)
PCTFE (formerly Kel-F® 81)	175° F (80° C)	@	3600 psig (24.82 MPa)
Polyimide	175° F (80° C)	@	3600 psig (24.82 MPa)
PEEK™	175° F (80° C)	@	3600 psig (24.82 MPa)

## Outline and Mounting Dimensions

Weight = 0.7 lbs (0.31kg)

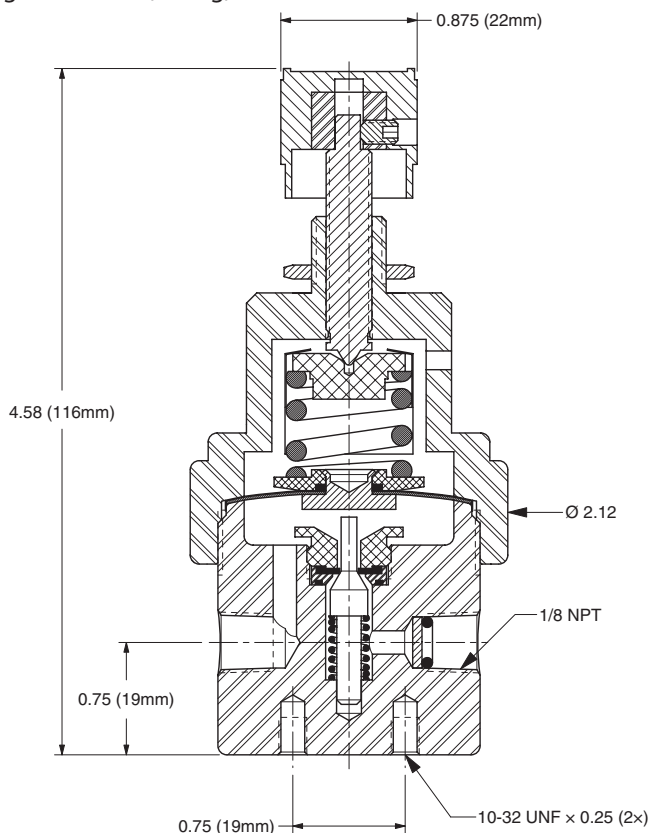

Teflon® and Tefzel® are registered trademarks of the DuPont Company.  
Viton® is a registered trademark of DuPont Dow Elastomers.  
Kel-F® is a registered trademark of 3M Company.  
PEEK™ is a trademark of Victrex PLC.

# Porting Configurations for Single Stage Pressure Regulators

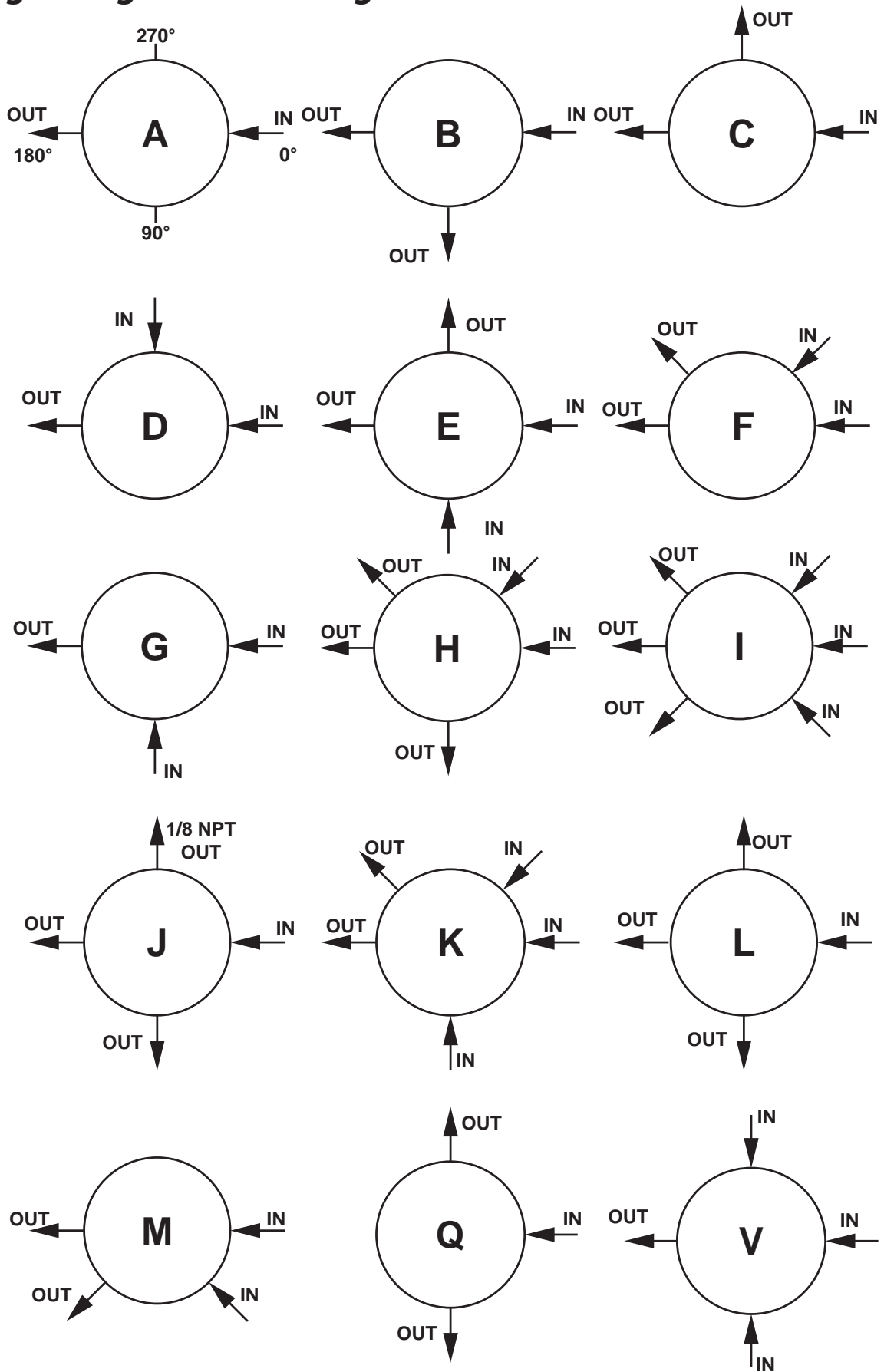

LOCATION OF PORTS FROM  
TOP VIEW