

# GO REGULATOR, INC.

A division of CIRCOR International, Inc.



## UCP-1 Precision Pressure Regulator

The model UCP-1 offers the user an ultra compact pressure regulator for use in high purity systems for the semiconductor industry. Meeting the highest purity standards and low particle generation of the semiconductor industry, this unit features internal components with standard surface finishes better than 25 Ra. The UCP-1 was computer designed to ensure a laminar flow transition from the flow control orifice to the outlet port. This design ensures virtually zero particle entrapment and efficient purge cycles.

### Features & Specifications

- 316 Stainless Steel Construction
- Inlet 300 psig max. with Viton® or Kalrez® Seats; 3600 psig max. with Tefzel®, Polyimide, or Kel-F Seats
- 1 x 10<sup>-9</sup> atm cc/sec, Inboard Leak Spec
- Outlet 10, 25, 50, 100, 250 and 500 psig
- C<sub>v</sub> Flow 0.025, 0.06, or 0.2
- 1/4" Male or Female VCR Compatible

### Applications

- Bulk Inert Gas Distribution
- Diffusion Furnaces
- Epitaxial Reactors
- Specialty Gas Distribution
- Manufacturing Tool

### Options

- Corrosion Resistant Materials of Construction
- 15 Ra, 10 Ra or 4 Ra internal surface finish

2301 Wardlow Circle  
Corona, CA 92880  
tel 909.270.6200  
fax 909.270.6201  
www.goreg.com  
sales@goreg.com

# UCP-1

## Precision Pressure Regulator

### How to Order

See page 3 for standard configurations. For additional configurations, consult the factory.  
See page 4 for port locations.

### Maximum Temperature & Operating Inlet Pressures

Seat Material	Maximum Temperature*	@	Maximum Operating Inlet Pressure
Tefzel®	150° F (66° C)	@	3600 psiG (24.82 MPa)
High Density Teflon®	150° F (66° C)	@	3600 psiG (24.82 MPa)
PCTFE (formerly Kel-F81)	175° F (80° C)	@	6000 psiG (41.37 MPa)
Polyimide	500° F (260° C)	@	3600 psiG (24.82 MPa)
Polyimide	175° F (80° C)	@	6000 psiG (41.37 MPa)
PEEK	500° F (260° C)	@	3600 psiG (24.82 MPa)
PEEK	175° F (80° C)	@	6000 psiG (41.37 MPa)

\*Temperatures in excess of 175° F (80° C) require the use of a metal knob or the tamper proof option.  
Tefzel® and Teflon® are registered trademarks of Dupont.

### Outline and Mounting Dimensions

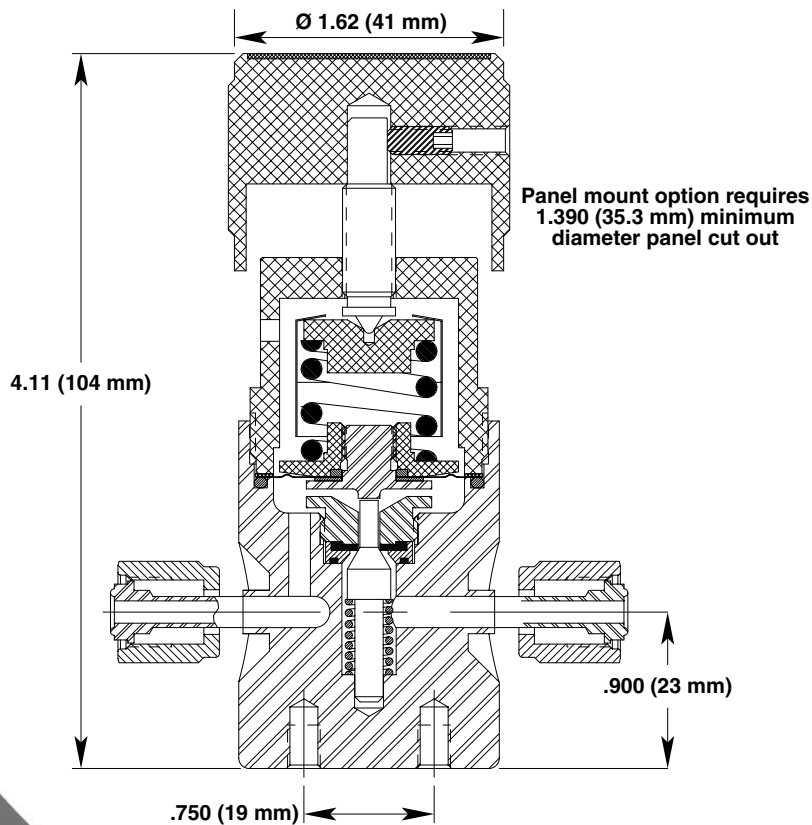

For flow curve information go to [www.goreg.com/flow\\_ucp1.htm](http://www.goreg.com/flow_ucp1.htm)

# UCP-1 Series - Pressure Reducing Regulator

1		S.S. 316L, Standard		<b>Material of Body</b>	
A		<b>Port Configuration (Ref. Dwg. 102191)</b>			
1		<b>Process &amp; Gauge ports</b>			
1	1/4" FVCR Process Ports, 1/4" FVCR Gauge Ports				
2	1/4" FVCR Process Ports, 1/4" MVCR Gauge Ports				
4	1/4" Swivel MVCR Process Ports, 1/4" FVCR Gauge Ports				
5	1/4" Swivel MVCR Process Ports, 1/4" Swivel MVCR Gauge Ports				
7	1/4" Tube Stubs at all Ports, 3.43 End to End (1.000 Stubs)				
8	1/4" Tube Stubs at all Ports, 7.43 End to End (3.000 Stubs)				
M	1/4" Fixed MVCR Process Ports, 1/4" FVCR Gauge Ports				
N	1/4" Fixed MVCR Process Ports, 1/4" Swivel MVCR Gauge Ports				
O	1/4" Fixed MVCR Process Ports, 1/4" Fixed MVCR Gauge Ports				
1		<b>Surface Finish of Diaphragm Cavity</b>			
1		<25 Ra			
A		<b>Seat Material</b>			
A	Tefzel				
C	Polyimide				
H	PCTFE (formerly Kel-F 81)				
I	High Density Teflon				
Q	PEEK				
3		<b>Flow Coefficient (Cv)</b>			
5		0.06			
C		0.2			
C		<b>Outlet Range</b>			
C	0 - 10 Psig				
D	0 - 25 Psig				
E	0 - 50 Psig				
G	0 - 100 Psig				
I	0 - 250 Psig				
J	0 - 500 Psig				
1		<b>Diaphragm Type</b>			
2		Standard Diaphragm			
2		Diaphragm Attached Poppet			
1		<b>O-Ring / Diaphragm Backing</b>			
7		Teflon / SS			
7		Viton / SS			
1		<b>Cap Assembly</b>			
4		Standard, Aluminum			
5		Panel Mount, Aluminum			
7		Captured Vent, Aluminum			
7		Captured Vent, S.S.			
B		Fine Adjust, 1 3/8" Panel Mount, Aluminum			

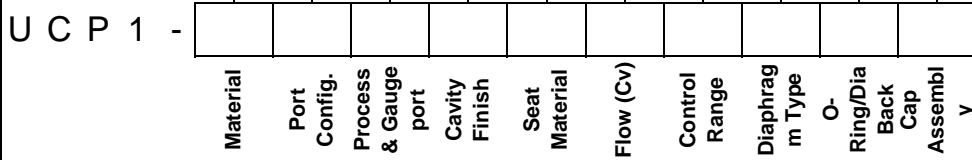

# PORT LOCATIONS (PRECISION PRESSURE REGULATOR)

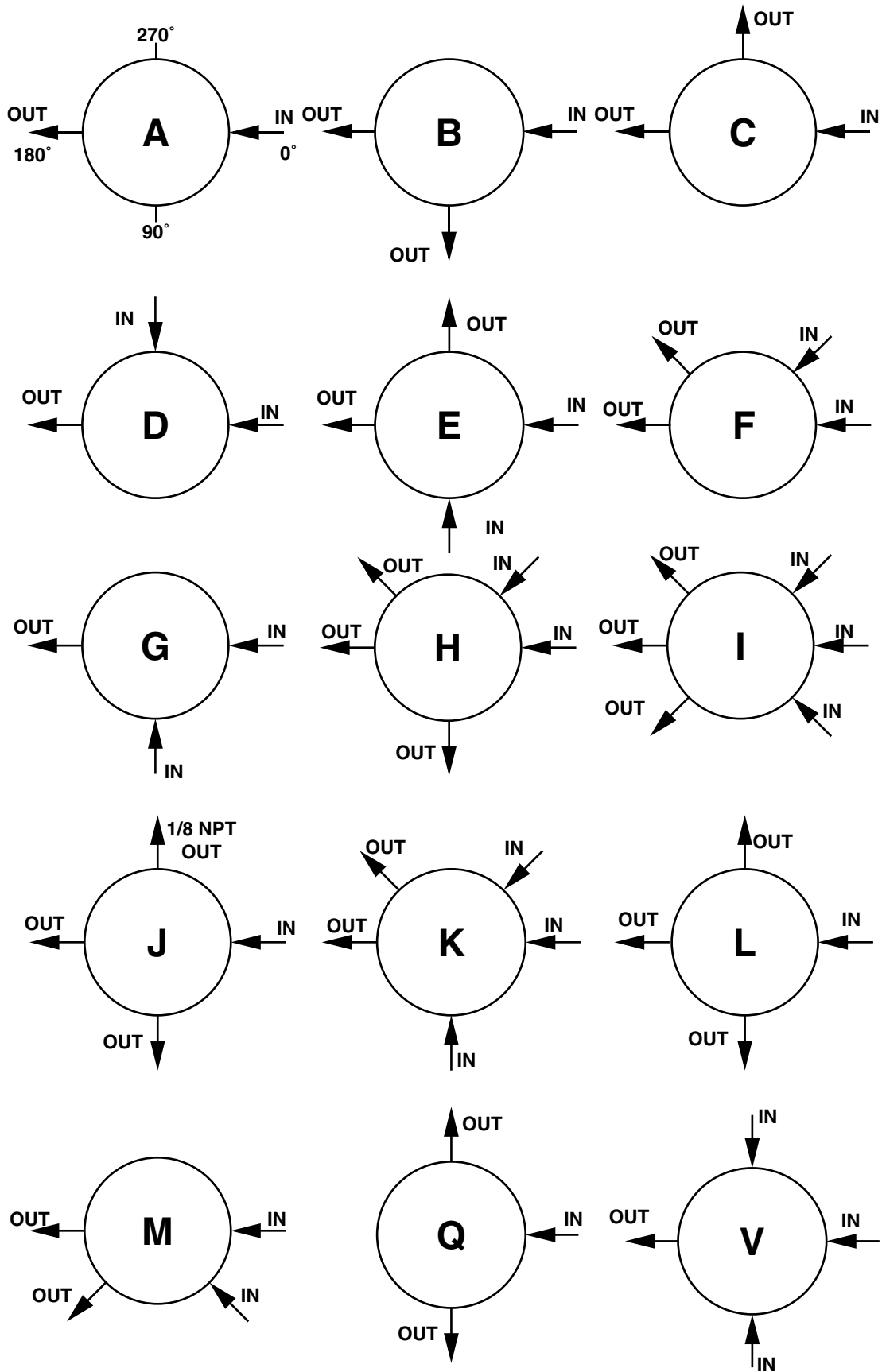

LOCATION OF PORTS FROM TOP VIEW